

SMD
application

Tip Style	A	B	F	D	E	BD	H	T	ZT	L
Material	B	B-S	B	B	B	B	B	B	S	B-S
∅ mm	0,74 1,52	0,74	0,74 1,22	0,74 1,02	1,22	0,74	1,22	1,22	0,74	0,74 1,02 1,22

Technical Data

Recommended Minimum Centers : 1,91 mm (.075)
 Current Rating : 3 A
 Typical Contact Resistance : 30 m Ω
 Recommended Working Travel : 1,78 mm (.070)

Materials

Barrel : Brass, gold plated
 Spring : Music Wire, silver / gold plated
 Plunger : Becu, hardened 24 Kt. gold plated

Max Travel : 2,54 mm (.100)

Spring Force : 108 gr.

Preload : 32 gr.

Receptacle

TKR-1

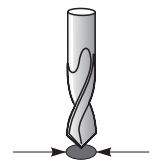
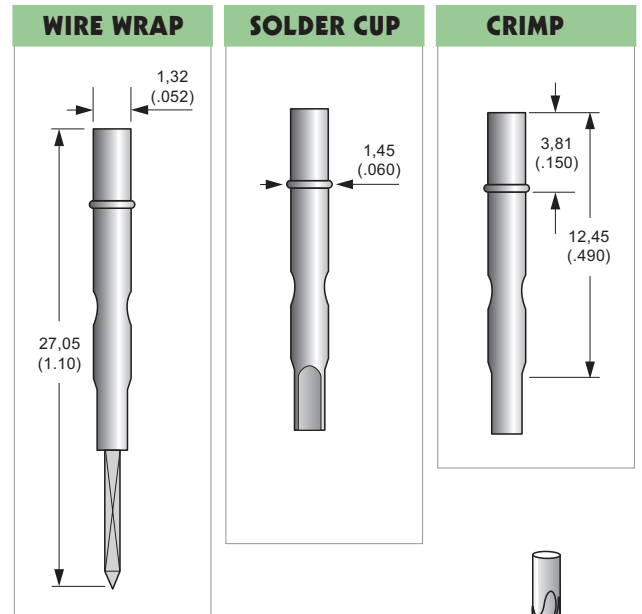

∅ 1,35
FR4 suggested drill diameter

How to Order:

Serie	Material	Plunger	∅	Spring Force	Galvanic
	B=Becu S=Steel				G = gold N = nickel R = rodim
TK-1	<input type="text"/>	<input type="text"/>	<input type="text"/>	<input type="text"/>	<input type="text"/>

How to Order:

TKR-1	<input type="text" value="W"/>
	C = Crimp S = Solder cup W = Wire wrap WW = With Wire