

Tip Style	A	B	F	D	E	H	H16	T	ZT	L	Q
Material	B	B-S	B	B	B	B	B	B-S	S	S	B-S
∅ mm	2,01 3,96	2,01	2,01 3,96	2,01 3,96	2,01 3,96	2,01 3,96	3,96	2,54	2,01	2,01 2,54 3,96	2,01

Receptacle

TKR-4

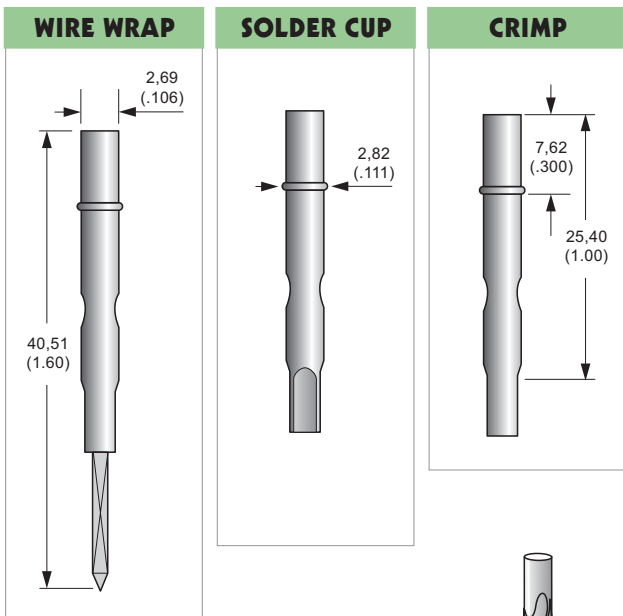

How to Order:

TKR-4

W

C = Crimp
S = Solder cup
W = Wire wrap
WW = With Wire

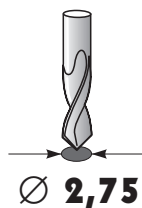

FR4 suggested drill diameter

Technical Data

Recommended Minimum Centers : 4,75 mm (.187)
Current Rating : 7,0 - 8,0 A
Typical Contact Resistance : 50 mΩ
Recommended Working Travel : 4,32 mm (.170)

Materials

Barrel : Brass, gold plated
Spring : Music Wire, silver / gold plated
Plunger : Becu, hardened 24 Kt. gold plated

Max Travel : 6,35 mm (.250) **Spring options :** 300 gr.

Spring Force : 200 gr.

Preload : 130 gr.

How to Order:

Serie	Material	Plunger	∅	Spring Force	Galvanic
TK-4	B=Becu S=Steel SS=Stainless St.				G = gold N = nickel R = rodium